

B2NF85H-QR20-CN4-2H1150

**Dynamic Inclinometer
CANopen**

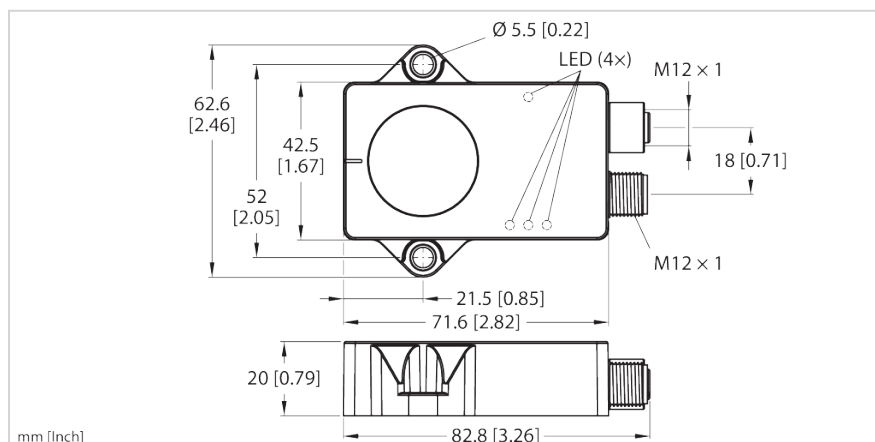

Typ	B2NF85H-QR20-CN4-2H1150
Ident-No.	100046440

Technical data

General data	
Measuring principle	Combination of gyroscopes and accelerometers
Detection area/measuring range	
Measuring range	-85...85 °
Number of measuring axes	2
Power supply	
Operating voltage U_B	8...36 VDC
Electrical data	
Baud rate	125/250/500/1000 kbps, factory setting 500 kbps
Wire break/reverse polarity protection	yes
Current consumption	< 80 mA
Isolation test voltage	≤ 0,5 kV
Node ID	1...127; Werkseinstellung: 10
Residual ripple	≤ 10 % U_{SS}
Interfaces	
Communication protocol	CANopen
Accuracy/deviation	

Features

- Rectangular, plastic, Ultem
- Status displayed via LED
- Angle detection over two axes with $\pm 85^\circ$ measuring range
- Recording of the rotation rate over three axes with a measuring range of $\pm 1000^\circ/s$
- Recording of the acceleration over three axes with a measuring range of $\pm 4 g$
- Temperature detection from -40...85 °C
- High protection class IP68/IP69K
- Increased interference immunity 100 V/m acc. to ISO 11452-2, 200 mA acc. to ISO 11452-4
- Protection against conducted interference acc. to ISO 7637-2 severity degree Level 4 and load dump acc. to ISO 16750-2 for 12-V/24-V systems
- Withstands rapid temperature change
- 8...36 VDC
- Connector, M12 x 1, 5-pin, CAN in, CAN out
- Acc. to CiA 301, CiA 305, CiA 410

Technical data

Resolution	16 bit
Resolution	≤0,01 °
Linearity deviation	0,15 %
Repeat accuracy	≤ 0,06 % v. E.
Temperature drift	≤ ±0,012 %/K

Mechanical data

Design	Rectangular, QR20
Construction type designation	QR20
Dimensions	71,6 mm x 62,6 mm x 20 mm
Housing material	Plastic, Ultem
Electrical connection	Connector, M12 × 1

Environmental conditions

Ambient temperature	-40...+85 °C
Temperature changes (EN60068-2-14)	-40... +85 °C; 20 cycles
Pollution degree	3
Shock resistance (EN 60068-2-27)	200 g; 4 ms ½ sine
Vibration resistance (EN 60068-2-6)	20 g; 5 h/axis; 3 axes
Protection class	IP68 IP69K

Tests/approvals

UL registration number	E351232
MTTF	339 Jahre acc. to SN 29500 (Ed. 99) 40 °C

Displays/controls

Measuring range display	LED, yellow
Power-on indication	LED, Green
Status CANopen	Green/red

Wiring diagram

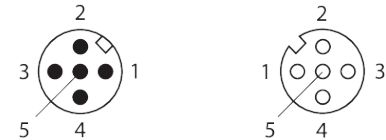
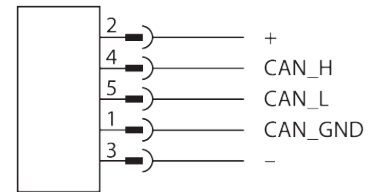

Functional principle

The dynamic inclinometers use an acceleration measuring cell and a gyroscope sensor to determine angles. Influences caused by vibrations or interfering acceleration are minimized by applying an intelligent fusion algorithm to the acceleration data and the rotation rate values. This enables the sensor to output a robust signal with impressive precision and speed, even in moving, dynamic applications.

The measuring principle used makes mounting and commissioning the device easy. The robust sensors are positioned with the cast side on a flat surface so that the casting compound is covered. The sensor is then secured with two screws.

The sensor can also record the temperature, which can be used to monitor the condition of the machine.

Installation instructions

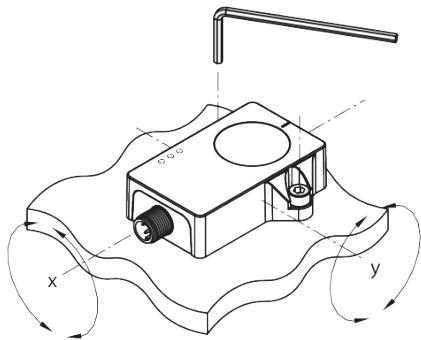

● 4 mm
3 Nm

Installation information:

The measuring principle used makes mounting and commissioning the device easy, e.g. because being adjacent to metal does not interfere with the measuring principle.

A green LED indicates whether the sensor is being properly supplied with power. In addition, LED displays indicate the status of the device and bus. One yellow LED per inclination axis acts as a zero-position indicator to aid commissioning. It is constantly illuminated when the position of the inclinometer is within a window of $\pm 0.5^\circ$ around the center point. The LED flashes with increasing frequency the nearer the sensor gets to the center point position.

Mounting accessories

GUARD-QR20

100027185

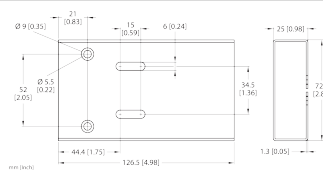

Protective housing for QR20 inclinometers for protecting against mechanical impact; material: stainless steel

MAGKIT-QR20

100051844

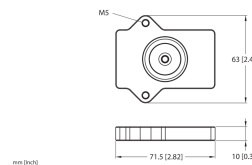

Mounting magnet for mounting the CMVT-QR20; includes two mounting screws; the magnetic mount for the sensor offers a flexible mounting option. Permanent and operationally secure fixing depends on the application conditions and must be evaluated by the user.

Connectivity accessories

RKC5701-5M

6931034

Bus cable for CAN (DeviceNet, CANopen), M12 female connector, straight, cable length: 5 m, jacket material: PUR, anthracite; cULus approval

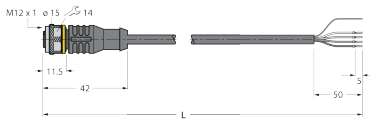

WKC5701-5M

6933244

Bus cable for CAN (DeviceNet, CANopen), M12 female connector, angled, cable length: 5 m, jacket material: PUR, anthracite; cULus approval

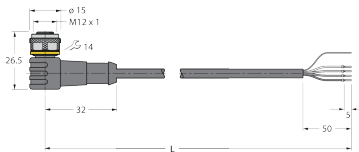

RSC5701-5M

6931036

Bus cable for CAN (DeviceNet, CANopen), M12 male connector, straight, cable length: 5 m, jacket material: PUR, anthracite; cULus approval

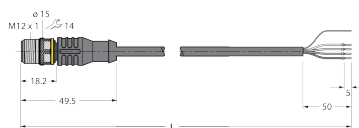

WSC5701-5M

6933247

Bus cable for CAN (DeviceNet, CANopen), M12 male connector, angled, cable length: 5 m, jacket material: PUR, anthracite; cULus approval

