

CMVT-M8TA1X-LI220-H1141

Vibration Sensor

For condition monitoring with 4...20 mA

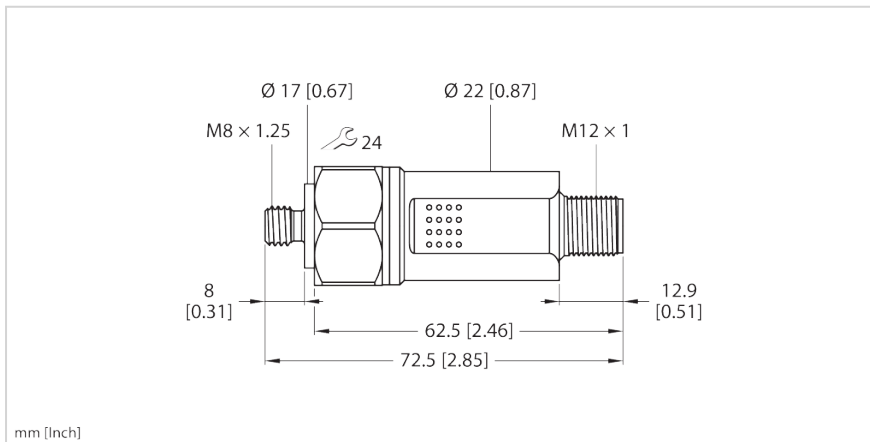

Typ	CMVT-M8TA1X-LI220-H1141
Ident-No.	100053262

Technical data

Vibration - Acceleration	
Sampling rate of the acceleration measuring cell	23,6 KHz
Vibration - Speed	
RMS measuring range	0...25 mm/s
Accuracy RMS, typical	≤ ±0,5 % @ 159 Hz
Power supply	
Operating voltage U_B	18...30 VDC
Electrical data	
Current consumption	< 100 mA
Residual ripple	≤ 10 % U_{SS}
Outputs	
Current output	4...20 mA
Load resistance current output	≤ 0,5 kΩ
Mechanical data	
Design	Cylinder, threaded
Dimensions	72,5 mm x 23,8 mm
Housing material	Stainless steel
Electrical connection	Connector, M12 × 1

Features

- Stainless steel housing with M8 screw-in thread
- Speed output RMS
- Detection over 1 axis
- 4...20 mA corresponds to 0...20 mm/s RMS
- High protection class IP66/IP67
- M12 × 1 connector, 4-pin

Technical data

Environmental conditions	
Ambient temperature	-40...+80 °C
Shock resistance (EN 60068-2-27)	60 g, 6 ms
Vibration resistance (EN 60068-2-6)	20 g; 5 h/axis; 3 axes
Protection class	IP66 IP67
Tests/approvals	
MTTF	164 Jahre acc. to SN 29500 (Ed. 99) 40 °C

Wiring diagram

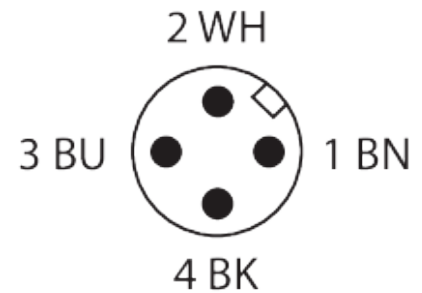
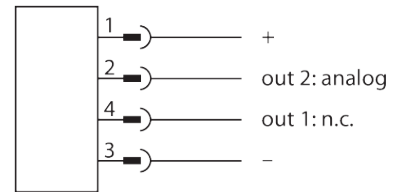

Typical frequency response

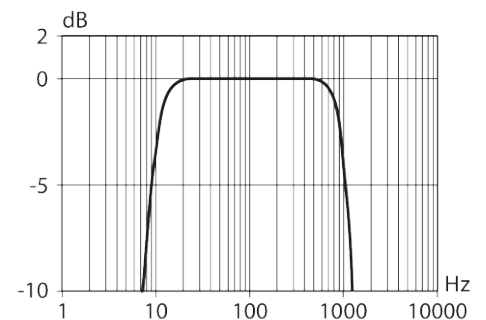

Functional principle

Condition monitoring sensors help to prevent unplanned downtimes and malfunctions during the production process. They monitor the condition of the machine as a preventative measure.

Using the CM sensors can prevent system downtime or machine damage, which in turn improves system effectiveness and allows uninterrupted operation.

The use of CMVT sensors also directly benefits the user in a quantifiable way. Information on vibration is output via the standardized 4...20-mA interface.

Installation instructions

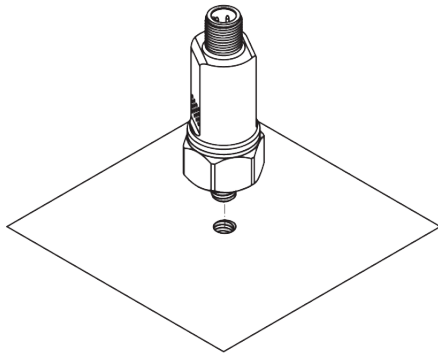

 24 mm
8 Nm

Installation information:

Using an M8 screw-in thread, the vibration sensors can be easily screwed into the component to be monitored and fastened into place.

If other thread sizes are present in the component to be monitored, a wide range of accessories including thread adapters is available.

Mounting accessories

MA-M8-1/2-BSPT **100050775**

M8 to 1/2" BSPT

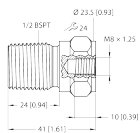

mm (inch)

MA-M8-1/4-NPT **100050776**

M8 to 1/4" NPT

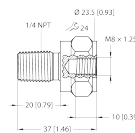

mm (inch)

MA-M8-1/4-UNF28G **100050777**

M8 to 1/4" UNF 28 G

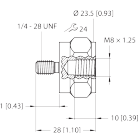

mm (inch)

MA-M8-3/4-24UNF2A **100050778**

M8 to 3/8" 24 UNF 2A

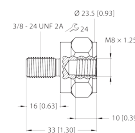

mm (inch)

MA-M8-M6 **100050779**

M8 to M6

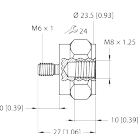

mm (inch)

MA-M8-M10 **100050780**

M8 to M10

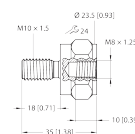

mm (inch)

MA-M8-M12 **100050781**

M8 to M12

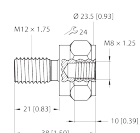

mm (inch)

MA-M8-M16 **100050782**

M8 to M16

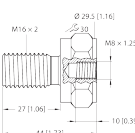

mm (inch)

MA-M8-M20 **100050783**

M8 to M20

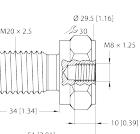

mm (inch)

MA-M8-M24 **100050784**

M8 to M24

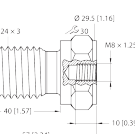

mm (inch)

Mounting accessories

MA-M8-M30

100050785

M8 to M30

