

**Pick-to-Light
placement sensor
pushbutton for picking processes
K30APPBMBYCQPMA**

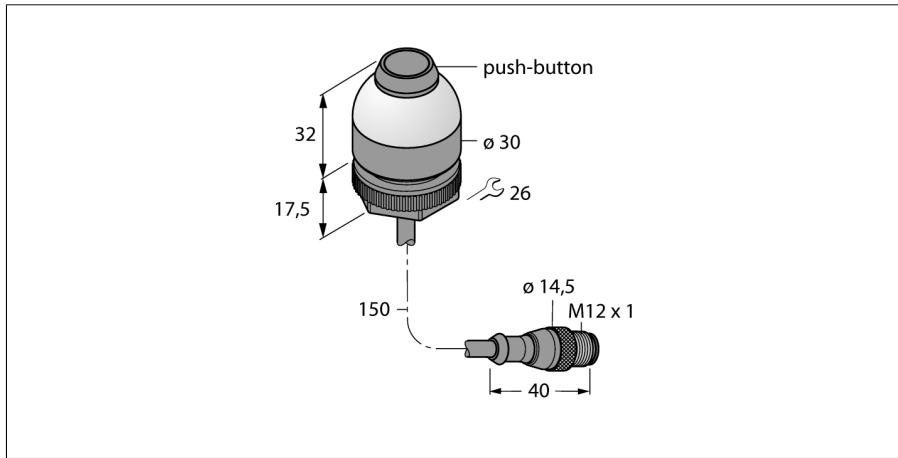

- Cable with male end M12 x 1, 4-pin, PUR, 150 mm
- Protection class IP65
- Job light: blue
- Mispick: not signalled
- Actuation: yellow
- Operating voltage 12...30 VDC
- PNP switching
- NO contact

Wiring diagram

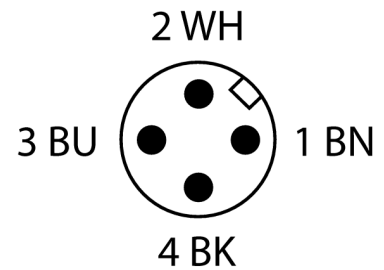
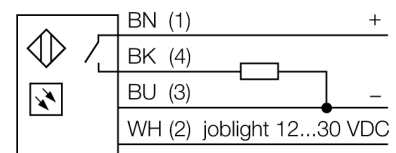

Type code	K30APPBMBYCQPMA
Ident no.	3019147
Purpose	Pick-to-Light pushbutton
Operating mode	no
Cascadable	no
Design	cylindrical/threaded
Housing material	plastic, PC
Connection	Cable with male end, M12 x 1, 4-wire
Electrical version	DC, NO contact, PNP
Cable length	0.15 m
Cable Jacket Material	PVC
IP Rating	IP67
Ambient temperature	-40...+70 °C
Operating voltage	12...30VDC
DC rated operational current	≤ 150 mA
Response time	< 1 ms
Dimmable	no

Functional principle

The K30 placement sensor is suitable for many assembly and placement sequences. The entire dome indicates the highly visible green job light or another signal (depending on the version). The transistor output can be easily connected to a system control which is programmed for a special task sequence. The job light of the sensor is located in or beside every container of the component placement station and signals: Detects 1. the containers with the components that have to be picked for a job and 2. the sequence in which they have to be removed. If the operator removes a part from the bin, the K30 detects the hand in the bin and sends a signal to the control unit. The system then checks if the correct component has been picked and switches – depending on the configuration – the corresponding job light off and switches on the next job light of the container which is next in the assembly sequence. The control of the working procedure leads to increased efficiency, improved quality control and reduces the rework and testing expense.

**Pick-to-Light
placement sensor
pushbutton for picking processes
K30APPBMBYCQPMa**

Accessories

Type code	Ident no.	Description	Design
SMB22A	3079414	Mounting bracket, stainless steel, for K30L series	

Wiring accessories

Type code	Ident no.	Description	Design
RKC4.4T-2/TEL	6625013	Connection cable, female M12, straight, 4-pin, cable length: 2 m, sheath material: PVC, black; cULus approval; other cable lengths and qualities available, see www.turck.com	
WKC4.4T-2/TEL	6625025	Connection cable, female M12, angled, 4-pin, cable length: 2 m, sheath material: PVC, black; cULus approval; other cable lengths and qualities available, see www.turck.com	