

Radar-Scanner MR...

Weitere Unterlagen

Ergänzend zu diesem Dokument finden Sie im Internet unter www.turck.com folgende Unterlagen:

- Datenblatt
- Betriebsanleitung
- IO-Link-Parameter
- IO-Link-Inbetriebnahmehandbuch
- Konformitätserklärungen
- Zulassungen

Zu Ihrer Sicherheit

Bestimmungsgemäße Verwendung

Die Radar-Scanner der Baureihe MR... erfassen berührungslos die Anwesenheit von Objekten im Erfassungsbereich und messen deren Position im Raum. Wenn sich mehrere Objekte im Erfassungsbereich befinden kann gewählt werden, ob das Objekt am nächsten zum Sensor oder das Objekt mit dem stärksten Echosignal ausgewertet werden soll. Erfassungsbereich und Objekterfassung können über Filtereinstellungen und Sensorkonfigurationen angepasst werden.

Die Geräte dürfen nur wie in dieser Anleitung beschrieben verwendet werden. Jede andere Verwendung gilt als nicht bestimmungsgemäß. Für daraus resultierende Schäden übernimmt TURCK keine Haftung.

Naheliegende Fehlanwendung

Die Geräte sind keine Sicherheitsbauteile und dürfen nicht zum Personenschutz eingesetzt werden.

Allgemeine Sicherheitshinweise

- Nur fachlich geschultes Personal darf das Gerät montieren, installieren, betreiben, parametrieren und instand halten.
- Die maximal emittierte Sendeleistung des Sensors übersteigt nicht die zugelassenen Grenzwerte nach ETSI EN 305550-2.

Hinweise zur UL-Zulassung

- Die Radarsensoren müssen mit einer gelisteten (CYJV/7 oder CYJV2/8) Kabel-/Steckverbinderbaugruppe mit einem Nennwert von mindestens 36 VDC und mindestens 500 mA verwendet werden, die für die Anwendung in der Endinstallation geeignet ist.

Produktbeschreibung

Geräteübersicht

Siehe Abb. 1: Geräteansicht, Abb. 2: Abmessungen.

Funktionen und Betriebsarten

Typ	Ausgang
MR...Q80-IOLCJ-H1141	IO-Link (SSP 4.1.1), 2 Schaltausgänge, SAE J1939

Das Gerät misst die Distanz zwischen dem Erfassungsobjekt und dem Ende des Sensorgehäuses, die jeweiligen Azimut- und Elevationswinkel, sowie die Radialgeschwindigkeit. Für die Schaltausgänge lassen sich ein Einzelschaltpunkt, zwei Schaltausgänge oder eine Fensterfunktion festlegen, sowohl für die Abstands-, Winkel- oder Geschwindigkeitskanäle. Zusätzlich werden die Messwerte über die IO-Link-Prozessdaten und über das SAE J1939-Protokoll an die übergeordnete Steuerungsebene gesendet. Der Abstandswert wird in m, der Winkel in ° und die Geschwindigkeit in m/s über die Prozessdaten übertragen.

Das Gerät ist über IO-Link und über das SAE J1939-Protokoll parametrierbar.

Technische Daten

Messbereich	0,35...15 m
Blindzone s_{min}	350 mm
Frequenzbereich	60...64 GHz
Auflösung	2 mm
Hysterese	≤ 50 mm
Umgebungstemperatur	-40...+85 °C
Betriebsspannung	9...33 V (SELV/PELV)
Leistungsaufnahme	max. 30 W (13 W intern, 17 W extern)
Bereitschaftsverzug	300 ms
Stecker 1	Schaltausgang und/oder IO-Link
Stecker 2	SAE J1939
Bemessungsbetriebsstrom	≤ 400 mA (Ausgänge ohne Last) ≤ 900 mA (Ausgänge mit Last) ≤ 250 mA (Ausgangslast pro Ausgang)
Schutzart	IP67, IP69K (nicht bewertet nach IEC und UL)
Gewicht	458 g
Elektromagnetische Verträglichkeit (EMV)	EN 61000-6-2:2019 ETSI EN 301489-3 V1.6.1
Luftfeuchtigkeit	0...99 % rel.
Max. Einsatzhöhe	2000 m
Verschmutzungsgrad	3
Nutzungsart	innen/außen

Montieren

Durch den Schriftzug „TURCK“ wird die Azimutachse des Sensors gekennzeichnet. Je nach Anwendungsfall dürfen die Sensoren in beliebiger Ausrichtung montiert werden. Die Radarwelle breitet sich senkrecht zur Radarlinsefläche aus. Der Erfassungsbereich kann in Abstand und Winkel kundenspezifisch eingestellt werden. Dabei ist der maximale Öffnungswinkel auf ±60° (Azimut) und ±50° (Elevation) beschränkt.

Das maximale Anziehdrehmoment bei der Befestigung des Sensors beträgt 7 Nm.

- ▶ Sensor am vorgesehenen Einsatzort montieren. Die Blindzone s_{min} beachten, in der keine Objekterfassung stattfindet (siehe technische Daten).

- ▶ Sensor so montieren, dass keine Fremdobjekte im Erfassungsbereich liegen (s. Abb. 3).

Anschließen

HINWEIS

Das Gerät muss aus SELV/PELV versorgt werden, das die Anforderungen an einen Stromkreis mit begrenzter Energie gemäß UL61010-1 3rd Edition (IEC/EN 61010-1) erfüllt oder aus Spannungsversorgung mit limitierter Energie gemäß UL 62368-1 oder Class 2 gemäß NEC.

- ▶ Gerät gemäß „Wiring diagrams“ anschließen.

In Betrieb nehmen

Nach Anschluss der Leitungen und Aufschalten der Versorgungsspannung geht das Gerät automatisch in Betrieb.

Betreiben

LED-Anzeigen

LED PWR	Bedeutung
grün	Sensor betriebsbereit (Signalstärke > 108 dB)
blinkt grün (4 Hz)	Signalstärke < 108 dB
blinkt grün (1 Hz)	Signalstärke < 78 dB
gelb	Ausgang 2 aktiv
blinkt gelb	Kurzschluss an Ausgang 2

LED COM	Bedeutung
grün	SIO-Modus
blinkt grün (5 Hz)	CAN-Verbindung aktiv
blinkt grün (900 ms an / 100 ms aus)	IO-Link-Kommunikation aktiv
gelb	Ausgang 1 aktiv
blinkt gelb	Kurzschluss an Ausgang 1
blinkt rot	Bus-Verbindung unterbrochen
blinkt grün/rot	Adressanforderung (nur J1939)

LED APP	Bedeutung
grün	Objekt im Erfassungsbereich
gelb	Objekt in Bereich 1
blinkt gelb	Objekt in Radius 1

Kombinierte Zustandsanzeigen

PWR	COM	APP	Bedeutung
rot (1 Hz)	rot (1 Hz)	rot (1 Hz)	interner Hardwarefehler
Laufflicht grün/gelb/rot	Laufflicht grün/gelb/rot	Laufflicht grün/gelb/rot	Firmware-Update aktiv
blinkt grün/gelb	blinkt grün/gelb	blinkt grün/gelb	Wink-Kommando zur Produktidentifizierung innerhalb der Anlage

Declaration of conformity

Hiermit erklärt die TURCK GmbH, dass die Radar-Scanner der Baureihe MR... der Richtlinie 2014/53/EU und den Radio Equipment Regulations 2017 entsprechen. Der vollständige Text der EU/UK-Konformitätserklärung ist unter der folgenden Internetadresse verfügbar: www.turck.com

Hereby, TURCK GmbH declares that the radar scanner series MR... are in compliance with Directive 2014/53/EU and Radio Equipment Regulations 2017. The full text of the EU/UK declaration of conformity is available at the following internet address: www.turck.com

FCC digital device limitations

FCC ID: YQ7-MR15Q80
IC ID: 8821A-MR15Q80

This device complies with Part 15 of the FCC Rules and Industry Canada license-exempt RSS standard(s). Operation is subject to the following two conditions:
(1) this device may not cause harmful interference, and
(2) this device must accept any interference received, including interference that may cause undesired operation.

Changes or modifications not expressly approved by the party responsible for compliance could void the user's authority to operate the equipment.

Datenübertragung über IO-Link SSP4

Die Datenübertragung über IO-Link SSP4 nutzt vier Kanäle:

Kanal	Zuordnung
1	Abstand
2	Azimutwinkel
3	Elevationswinkel
4	Geschwindigkeit

Datenübertragung über SAE J1939-Schnittstelle

- Die Datenübertragung über die SAE J1939-Schnittstelle verwendet die Parameter-Gruppe PGN 0xFF20 (65315).
- Die Objektdaten werden von dem ersten oder stärksten (einstellbar in den Sensorparametern) erkannten Objekt im Erfassungsbereich generiert.

Byte	Zuordnung
0	Abstand
1	Abstand
2	Azimutwinkel
3	Elevationswinkel
4	Geschwindigkeit
5	Signalstärke
6	Warnradiusinformation (Bit 2...7)
7	Signalfelderinformation (Bit 2...7)

Einstellen und Parametrieren

Die Parametrierung über IO-Link ist im IO-Link-Inbetriebnahmehandbuch beschrieben. Am Sensor können folgende Eigenschaften verändert werden, um das Verhalten des Sensors einzustellen:

- Vorder- und Hintergrundausblendung
- Winkelausblendung (Azimut und Elevation)
- Signalintensitätsfilter
- Erkennung nur bewegter oder aller Objekte
- 6 Warn-/Alarmradien um den Sensor
- 3 Signalfelder im Erfassungsbereich

Instand halten

Das Gerät ist wartungsfrei, bei Bedarf mit einem feuchten Tuch reinigen.

Reparieren

Sollte das Gerät defekt sein, nehmen Sie es außer Betrieb. Das Gerät darf nur durch TURCK repariert werden. Bei Rücksendung an TURCK beachten Sie bitte unsere Rücknahmebedingungen.

Entsorgen

Die Geräte müssen fachgerecht entsorgt werden und gehören nicht in den normalen Hausmüll.

①



MR...
Radar Scanner
Quick Start Guide
Doc. no. 100045077

Additional
information see



②

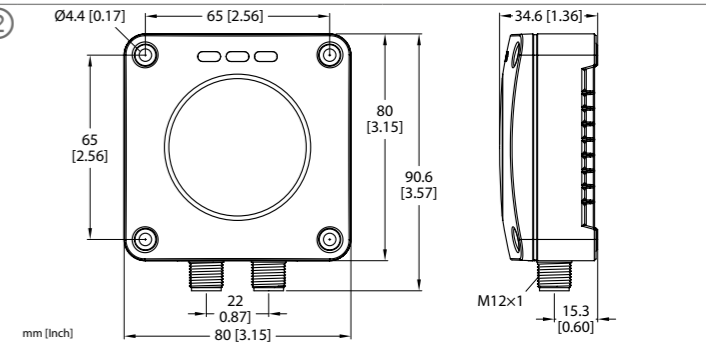

③

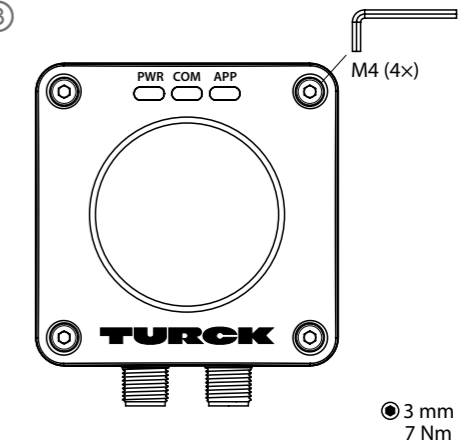

Wiring diagrams

Connector 1 (IO-Link and switching outputs)

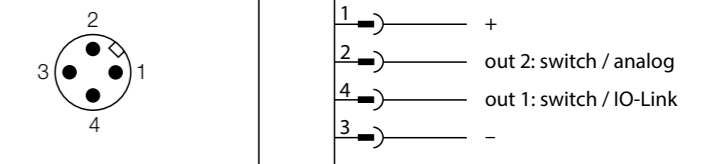

Connector 2 (SAE J1939)

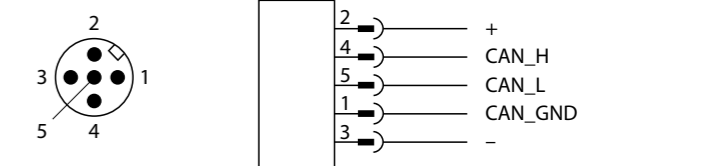

Radar Scanner MR...

Other documents

Besides this document, the following material can be found on the Internet at www.turck.com:

- Data sheet
- Instructions for use
- IO-Link parameters
- IO-Link commissioning manual
- Declarations of conformity
- Approvals

For your safety

Intended use

The radar scanners in the MR... product series detect the presence of objects within a detection range without contact and measure the position of these objects within the space. If there are several objects within the detection range, you can choose whether the object closest to the sensor or the object with the strongest echo signal should be evaluated. Detection range and object detection can be adjusted via filter settings and sensor configurations.

The devices must only be used as described in these instructions. Any other use is not in accordance with the intended use. TURCK accepts no liability for any resulting damage.

Obvious misuse

The devices are not safety components and must not be used for personal protection.

General safety instructions

- The device must only be mounted, installed, operated, parameterized and maintained by trained and qualified personnel.
- Do not use the device for the protection of persons or machines.
- The maximum emitted transmission power of the sensor does not exceed the permitted limits according to ETSI EN 305550-2.

Notes on the UL approval

- The radar sensors must be used with a listed (CYJV/7 or CYJV2/8) cable/connector assembly with a rated value of at least 36 VDC and at least 500 mA which is suitable for the application in the final installation.

Product description

Device overview

See fig. 1: Device view, fig. 2: Dimensions.

Functions and operating modes

Type	Output
MR...-Q80-IOLCJ-H1141	IO-Link (SSP 4.1.1), 2 switching outputs, SAE J1939

The device measures the distance between the detected object and the end of the sensor housing; it also measures the respective azimuth and elevation angles and the radial velocity. For the switching outputs, a single switching point, two switching outputs or a window function can be defined for the distance, angle or velocity channels. In addition, the measured values are sent to the higher-level control system via the IO-Link process data and via the SAE J1939 protocol. The distance value is transmitted in m, the angle in ° and the speed in m/s via the process data.

The device can be parameterized via IO-Link and via the SAE J1939 protocol.

Technical data

Measuring range	0.35...15 m
Blind zone s_{min}	350 mm
Frequency range	60...64 GHz
Resolution	2 mm
Hysteresis	≤ 50 mm
Ambient temperature	-40...+85 °C
Operating voltage	9...33 V (SELV/PELV)
Power consumption	max. 30 W (13 W internal, 17 W external)
Readiness delay	300 ms
Male connector 1	Switching output and/or IO-Link
Male connector 2	SAE J1939
Rated power	≤ 400 mA (Outputs without loads) ≤ 900 mA (Outputs loaded) ≤ 250 mA (Output load per output)
Protection class	IP67, IP69K (not evaluated acc. IEC and UL)
Weight	458 g
Electromagnetic compatibility (EMC)	EN 61000-6-2:2019 ETSI EN 301489-3 V1.6.1
Humidity	0...99 % rel.
max. altitude	2000 m
Pollution degree	3
Type of use	indoor/outdoor

Installing

The "TURCK" lettering indicates the sensor's azimuth axis.

The sensors can be installed in any alignment according to application requirements. The radar wave propagates perpendicular to the surface of the radar lens. The distance and angle of the detection range can be set to customer specifications. The maximum cone angle is limited to ±60° (azimuth) and ±50° (elevation).

The maximum tightening torque when mounting the sensor is 7 Nm.

- ▶ Install the sensor at the intended location. Be aware of the blind zone s_{min} in which no object detection is possible (see technical data).
- ▶ Install the sensor in such a way that no foreign objects are located in the detection range (see fig. 3).

Connection

NOTE

The device must be provided with an SELV/PELV power supply that is compliant with the requirements for a limited energy circuit in accordance with UL61010-1 3rd Edition (IEC/EN 61010-1) or from a limited power source in accordance with UL 62368-1 or Class 2 in accordance with NEC.

- ▶ Connect the device as shown in "Wiring diagrams."

Commissioning

The device is operational automatically once the cables are connected and the power supply is switched on.

Operation

LEDs

PWR LED	Meaning
Green	Sensor ready for operation (signal strength > 108 dB)
Green flashing (4 Hz)	Signal strength < 108 dB
Green flashing (1 Hz)	Signal strength < 78 dB
Yellow	Output 2 active
Yellow flashing	Short circuit at output 2

COM LED	Meaning
Green	SIO mode
Green flashing (5 Hz)	CAN connection active
Green flashing (900 ms on/100 ms off)	IO-Link communication active
Yellow	Output 1 active
Yellow flashing	Short circuit at output 1
Red flashing	Bus connection interrupted
Green/red flashing	Address request (J1939 only)

APP LED	Meaning
Green	Object within detection range
Yellow	Object in range 1
Yellow flashing	Object in radius 1

Combined status displays

PWR	COM	APP	Meaning
Red (1 Hz)	Red (1 Hz)	Red (1 Hz)	Internal hardware error
Green/yellow/red running light	Green/yellow/red running light	Green/yellow/red running light	Firmware update active
Green/yellow flashing	Green/yellow flashing	Green/yellow flashing	Wink command for product identification inside the system

Declaration of conformity

Hiermit erklärt die TURCK GmbH, dass die Radar-Scanner der Baureihe MR... der Richtlinie 2014/53/EU und den Radio Equipment Regulations 2017 entsprechen. Der vollständige Text der EU/UK-Konformitätserklärung ist unter der folgenden Internetadresse verfügbar: www.turck.com

Hereby, TURCK GmbH declares that the radar scanner series MR... are in compliance with Directive 2014/53/EU and Radio Equipment Regulations 2017. The full text of the EU/UK declaration of conformity is available at the following internet address: www.turck.com

FCC digital device limitations

FCC ID: YQ7-MR15Q80
IC ID: 8821A-MR15Q80

This device complies with Part 15 of the FCC Rules and Industry Canada license-exempt RSS standard(s). Operation is subject to the following two conditions:

- (1) this device may not cause harmful interference, and
- (2) this device must accept any interference received, including interference that may cause undesired operation.

Changes or modifications not expressly approved by the party responsible for compliance could void the user's authority to operate the equipment.

Data transfer via IO-Link SSP4

Data transfer via IO-Link SSP4 uses four channels:

Channel	Assignment
1	Distance
2	Azimuth angle
3	Elevation angle
4	Velocity

Data transfer via SAE J1939 interface

- Data transfer via the SAE J1939 interface uses the parameter group PGN 0xFF20 (65315).
- The object data is generated by the first or strongest object (depending on sensor settings) that is detected within the detection range.

Byte	Assignment
0	Distance
1	Distance
2	Azimuth angle
3	Elevation angle
4	Velocity
5	Signal strength
6	Warning radius information (bits 2...7)
7	Signal field information (bits 2...7)

Setting and parameterization

Parameterization via IO-Link is explained in the IO-Link commissioning manual.

The following properties can be changed on the sensor to adjust its behavior:

- Foreground and background suppression
- Angle suppression (azimuth and elevation)
- Signal intensity filter
- Detection of only moving objects or all objects
- 6 warning/alarm radii around the sensor
- 3 signal fields in the detection range

Maintenance

The device is maintenance-free. Clean with a damp cloth if required.

Repair

The device must be decommissioned if it is faulty. The device may only be repaired by TURCK. Observe our return acceptance conditions when returning the device to TURCK.

Disposal

The devices must be disposed of properly and do not belong in the domestic waste.

①



MR...
Radar Scanner
Quick Start Guide
Doc. no. 100045077

Additional information see



②

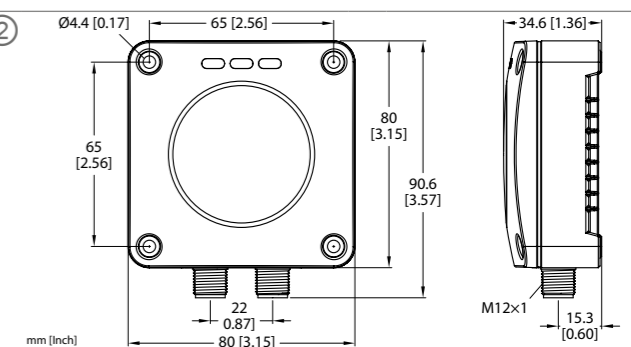

③

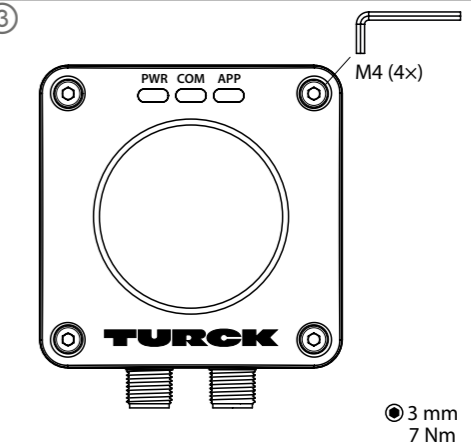

Wiring diagrams

Connector 1 (IO-Link and switching outputs)

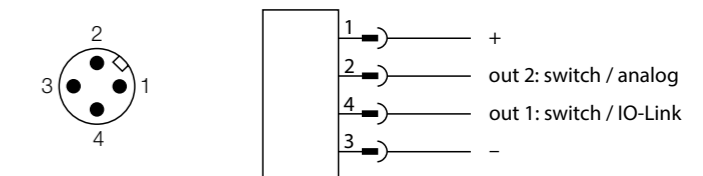

Connector 2 (SAE J1939)

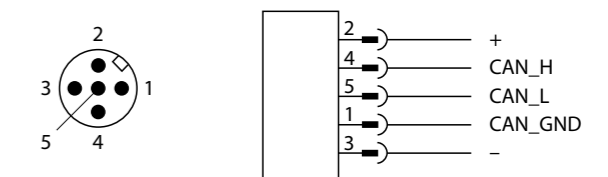

Le présent appareil est conforme aux CNR d'Industrie Canada applicables aux appareils radio exempts de licence. L'exploitation est autorisée aux deux conditions suivantes :

- (1) l'appareil ne doit pas produire de brouillage, et
- (2) l'utilisateur de l'appareil doit accepter tout brouillage radioélectrique subi, même si le brouillage est susceptible d'en compromettre le fonctionnement.

Note:

This equipment has been tested and found to comply with the limits for a Class A digital device, pursuant to part 15 of the FCC Rules. These limits are designed to provide reasonable protection against harmful interference when the equipment is operated in a commercial environment.

This equipment generates, uses, and can radiate radio frequency energy and, if not installed and used in accordance with the instruction manual, may cause harmful interference to radio communications. Operation of this equipment in a residential area is likely to cause harmful interference in which case the user will be required to correct the interference at his own expense.

Radiofrequency radiation exposure Information:

This equipment complies with FCC radiation exposure limits set forth for an uncontrolled environment. This equipment should be installed and operated with minimum distance of 20 cm between the radiator and your body.

This transmitter must not be co-located or operating in conjunction with any other antenna or transmitter.

Scanner radar MR...

Documents supplémentaires

Sous www.turck.com vous trouverez les documents suivants, qui contiennent des informations complémentaires à la présente notice :

- Fiche technique
- Mode d'emploi
- Paramètres IO-Link
- Manuel de mise en service IO-Link
- Déclarations de conformité
- Homologations

Pour votre sécurité

Utilisation conforme

Les scanners radar de la série MR... détectent sans contact la présence d'objets dans une plage de détection et mesurent la position de ces objets dans l'espace. Si plusieurs objets se trouvent dans la plage de détection, vous pouvez choisir d'évaluer l'objet le plus proche du capteur ou l'objet dont le signal d'écho est le plus fort. La plage de détection et la détection d'objet peuvent être paramétrées à l'aide des réglages de filtre et des configurations du capteur. Les appareils ne doivent être utilisés que conformément aux instructions figurant dans ce guide. Toute autre utilisation est non conforme. TURCK décline toute responsabilité en cas de dommages causés par une utilisation non conforme.

Mauvaises utilisations prévisibles

Les appareils ne constituent pas des composants de sécurité et ne peuvent pas être utilisés à des fins de protection des personnes.

Consignes de sécurité générales

- Seul un personnel dûment formé et qualifié peut monter, installer, utiliser, paramétrer et entretenir l'appareil.
- L'appareil ne peut pas être utilisé à des fins de protection des personnes ou des machines.
- La puissance d'émission maximale du capteur ne dépasse pas les limites autorisées selon la norme ETSI EN 305550-2.

Remarques concernant l'homologation UL

- Les capteurs radar doivent être utilisés avec un ensemble de câbles/connecteurs homologués (CYJV/7 ou CYJV2/8) d'une valeur nominale d'au moins 36 VDC et d'au moins 500 mA, adapté à l'utilisation dans l'installation finale.

Description du produit

Aperçu de l'appareil

Voir fig. 1 : Vue de l'appareil, fig. 2 : dimensions.

Fonctions et modes de fonctionnement

Type	Sortie
MR...-Q80-IOLCJ-H1141	IO-Link (SSP 4.1.1), 2 sorties de commutation, SAE J1939

L'appareil mesure la distance entre l'objet détecté et l'extrémité du boîtier du capteur ; il mesure également les angles d'azimut et d'élévation ainsi que la vitesse radiale. Pour les sorties de commutation, un seul point de commutation, deux sorties de commutation ou une fonction de fenêtre peuvent être définis pour les canaux de distance, d'angle ou de vitesse. En outre, les valeurs mesurées sont envoyées au système de commande de niveau supérieur via les données de processus IO-Link et le protocole SAE J1939. La valeur de la distance est transmise en m, l'angle en ° et la vitesse en m/s via les données de processus.

L'appareil peut être configuré via IO-Link et le protocole SAE J1939.

Données techniques

Plage de mesure	0,35...15 m
Angle mort s_{min}	350 mm
Plage de fréquences	60...64 GHz
Résolution	2 mm
Hystérésis	≤ 50 mm
Température ambiante	-40...+85 °C
Tension de service	9...33 V (SELV/PELV)
Consommation électrique	max.30 W (13 W interne, 17 W externe)
Retard à la disponibilité	300 ms
Connecteur mâle 1	Sortie de commutation (PNP) ou IO-Link
Connecteur mâle 2	SAE J1939
Puissance nominale	≤ 400 mA (sorties sans charges) ≤ 900 mA (sorties chargées) ≤ 250 mA (charge de sortie par sortie)
Indice de protection	IP67, IP69K (non évalué selon CEI et UL)
Masse	458 g
Compatibilité électromagnétique (CEM)	EN 61000-6-2:2019 ETSI EN 301489-3 v.1.6.1
Humidité atmosphérique	0...99 % rel.
max. altitude	2000 m
Degré de pollution	3
Type d'utilisation	intérieur/extérieur

Installation

L'inscription « TURCK » indique l'axe d'azimut du capteur.

Selon le cas d'utilisation, les capteurs peuvent être montés dans l'orientation de votre choix. L'onde radar se propage perpendiculairement à la surface de la lentille du radar. La distance et l'angle de la plage de détection peuvent être réglés selon les spécifications du client. L'angle maximal du cône est limité à ±60° (azimut) et ±50° (élévation).

Le couple de serrage maximal lors de la fixation du capteur s'élève à 7 Nm.

- Installez le capteur à l'emplacement prévu. Prenez en compte la zone morte s_{min} dans laquelle aucune détection d'objet n'est possible (voir « Technical data »).

- Montez le capteur de manière à ce qu'aucun objet étranger ne se trouve dans la plage de détection (voir fig. 3).

Raccordement

REMARQUE

L'appareil doit disposer d'une alimentation SELV/PELV qui répond aux exigences d'un circuit à énergie limitée conformément à la norme UL61010-1 3e édition (IEC/EN 61010-1) ou d'une source d'énergie limitée conformément à la norme UL 62368-1 ou à la classe 2 conformément à la NEC.

- Raccordez l'appareil conformément aux « Wiring diagrams ».

Mise en service

L'appareil se met automatiquement en marche suite au raccordement des câbles et à la mise sous tension.

Fonctionnement

LED	Signification
LED Pwr	
Vert	Capteur prêt à fonctionner (intensité du signal > 108 dB)
Vert clignote (4 Hz)	Intensité du signal < 108 dB
Vert clignote (1 Hz)	Intensité du signal < 78 dB
Jaune	Sortie 2 active
Jaune clignote	Court-circuit à la sortie 2
LED COM	
Vert	Mode SIO
Vert clignote (5 Hz)	Connexion CAN active
Vert clignote (900 ms on/100 ms off)	Communication IO-Link active
Jaune	Sortie 1 active
Jaune clignote	Court-circuit à la sortie 1
Rouge clignote	Connexion bus interrompue
Vert/rouge clignote	Demande d'adresse (J1939 uniquement)
LED APP	
Vert	Objet dans la plage de détection
Jaune	Objet dans la plage 1
Jaune clignote	Objet dans le rayon 1

Affichage de l'état combiné

PWR	COM	APP	Signification
Rouge (1 Hz)	Rouge (1 Hz)	Rouge (1 Hz)	Défaillance matérielle interne
Voyant vert/jaune/rouge	Voyant vert/jaune/rouge	Voyant vert/jaune/rouge	Mise à jour du micrologiciel active
Vert/jaune clignote	Vert/jaune clignote	Vert/jaune clignote	Commande wink pour l'identification du produit à l'intérieur du système

Transfert de données via IO-Link SSP4

Le transfert de données via IO-Link SSP4 utilise quatre canaux :

Canal	Configuration
1	Distance
2	Angle d'azimut
3	Angle d'élévation
4	Vitesse

Transfert de données via l'interface SAE J1939

- Le transfert de données via l'interface SAE J1939 utilise le groupe de paramètres PGN 0xFF20 (65315).
- Les données relatives à l'objet sont générées par le premier objet ou l'objet le plus fort (en fonction des réglages du capteur) détecté dans la plage de détection.

Octet	Configuration
0	Distance
1	Distance
2	Angle d'azimut
3	Angle d'élévation
4	Vitesse
5	Intensité du signal
6	Informations de rayon d'avertissement (bits 2...7)
7	Informations sur le champ de signal (bits 2...7)

Réglages et paramétrages

Le paramétrage via IO-Link est expliqué dans le manuel de mise en service IO-Link.

Les propriétés suivantes peuvent être modifiées sur le capteur pour ajuster son comportement :

- Suppression de premier et d'arrière-plan
- Suppression de l'angle (azimut et élévation)
- Filtre d'intensité de signal
- Détection des objets en mouvement uniquement ou de tous les objets
- 6 rayons d'avertissement/d'alarme autour du capteur
- 3 champs de signal dans la plage de détection

Entretien

L'appareil ne nécessite pas d'entretien. Nettoyez avec un chiffon humide si nécessaire.

Réparation

En cas de dysfonctionnement, mettez l'appareil hors service. L'appareil ne doit être réparé que par TURCK. En cas de retour à TURCK, veuillez respecter nos conditions de retour.

Mise au rebut

Les appareils doivent être mis au rebut de manière appropriée et ne doivent pas être jetés avec les ordures ménagères.

Le présent appareil est conforme aux CNR d'Industrie Canada applicables aux appareils radio exempts de licence. L'exploitation est autorisée aux deux conditions suivantes :

- (1) l'appareil ne doit pas produire de brouillage, et
- (2) l'utilisateur de l'appareil doit accepter tout brouillage radioélectrique subi, même si le brouillage est susceptible d'en compromettre le fonctionnement.

Note:

This equipment has been tested and found to comply with the limits for a Class A digital device, pursuant to part 15 of the FCC Rules. These limits are designed to provide reasonable protection against harmful interference when the equipment is operated in a commercial environment.

This equipment generates, uses, and can radiate radio frequency energy and, if not installed and used in accordance with the instruction manual, may cause harmful interference to radio communications. Operation of this equipment in a residential area is likely to cause harmful interference in which case the user will be required to correct the interference at his own expense.

Radiofrequency radiation exposure Information:

This equipment complies with FCC radiation exposure limits set forth for an uncontrolled environment. This equipment should be installed and operated with minimum distance of 20 cm between the radiator and your body.

This transmitter must not be co-located or operating in conjunction with any other antenna or transmitter.

①



MR...
Radar Scanner
Quick Start Guide
Doc. no. 100045077

Additional information see



②

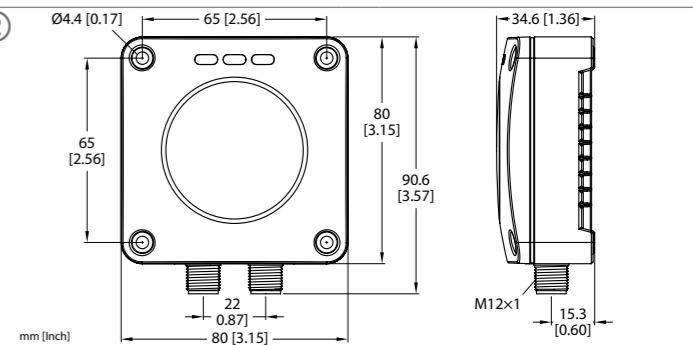

③

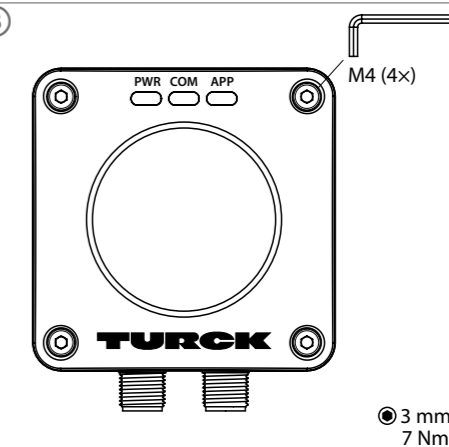

Wiring diagrams

Connector 1 (IO-Link and switching outputs)

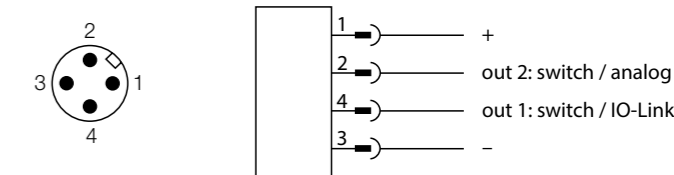

Connector 2 (SAE J1939)

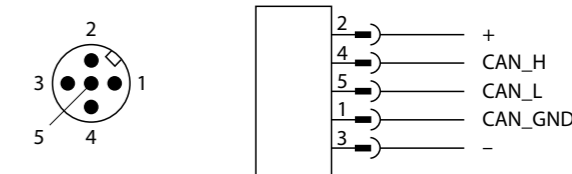

Escáner de radar MR...

Documentos adicionales

Además de este documento, se puede encontrar el siguiente material en Internet en www.turck.com:

- Hoja de datos
- Instrucciones de funcionamiento
- Parámetros de IO-Link
- Manual de puesta en marcha de IO-Link
- Declaración de conformidad
- Aprobaciones

Para su seguridad

Uso previsto

Los escáneres de radar de la serie de productos MR... detectan la presencia de objetos dentro de un campo de detección sin contacto y miden la posición de estos objetos dentro del espacio. Si hay varios objetos dentro del campo de detección, puede elegir si debe evaluarse el objeto más cercano al sensor o el objeto con la señal de eco más intensa. Se pueden ajustar el rango de detección y la detección de objetos mediante ajustes de filtros y configuraciones del sensor.

Los dispositivos solo se deben usar como se describe en estas instrucciones. Ninguna otra forma de uso corresponde al uso previsto. TURCK no se responsabiliza de los daños derivados de dichos usos.

Uso indebido evidente

Los dispositivos no son componentes de seguridad y no se deben utilizar para protección personal.

Instrucciones generales de seguridad

- Solo personal capacitado profesionalmente debe montar el dispositivo, instalarlo, operarlo, parametrizarlo y hacerle mantenimiento.
- No utilice el dispositivo para la protección de personas o máquinas.
- La potencia de transmisión máxima emitida por el sensor no supera los límites permitidos según la norma ETSI EN 305550-2.

Notas sobre la aprobación UL

- Los sensores de radar deben utilizarse con un conjunto de cable/conector registrado (CYJV/7 o CYJV2/8) con un valor nominal de al menos 36 VCC y al menos 500 mA que sea adecuado para la aplicación en la instalación final.

Descripción del producto

Descripción general del dispositivo

Consulte la fig. 1: Vista del dispositivo, fig. 2: Dimensiones.

Funciones y modos de operación

Tipo	Salida
MR...Q80-IOLCJ-H1141	IO-Link (SSP 4.1.1), 2 salidas de conmutación, SAE J1939

El dispositivo mide la distancia entre el objeto detectado y el extremo de la carcasa del sensor; también mide los respectivos ángulos acimutal y de elevación y la velocidad radial. Para las salidas de conmutación, se puede definir un único punto de conmutación, dos salidas de conmutación o una función de ventana para los canales de distancia, ángulo o velocidad. Además, los valores medidos se envían al sistema de control de nivel superior a través de los datos de proceso IO-Link y mediante el protocolo SAE J1939. El valor de la distancia se transmite en m, el ángulo en ° y la velocidad en m/s a través de los datos de proceso. El dispositivo se puede parametrizar a través de IO-Link y a través del protocolo SAE J1939.

Datos técnicos

Rango de medición	0,35...15 m
s_{\min} de zona ciega	350 mm
Rango de frecuencias	60...64 GHz
Resolución	2 mm
Histéresis	≤50 mm
Temperatura ambiente	-40...+85 °C
Voltaje de funcionamiento	9...33 V (SELV/PELV)
Consumo de potencia	máx. 30 W (13 W interno, 17 W externo)
Retardo de disponibilidad	300 ms
Conector macho 1	Salida de conmutación o IO-Link
Conector macho 2	SAE J1939
Potencia nominal	≤400 mA (salidas sin cargas) ≤900 mA (salidas cargadas) ≤250 mA (carga de salida por salida)
Grado de protección	IP67, IP69K (no evaluado según IEC y UL)
Peso	458 g
Compatibilidad electromagnética (CEM)	EN 61000-6-2:2019 ETSI EN 301489-3 V1.6.1
Humedad	0...99 % rel.
altitud máxima	2000 m
Grado de contaminación	3
Tipo de uso	interior y exterior

Instalación

Las letras "TURCK" indican el eje acimutal del sensor.

Los sensores se pueden instalar en cualquier alineación de acuerdo con los requisitos de la aplicación. La onda del radar se propaga perpendicularmente a la superficie de la lente del radar. La distancia y el ángulo del rango de detección pueden ajustarse según las especificaciones del cliente. El ángulo máximo del cono está limitado a ±60° (acimutal) y ±50° (elevación).

El par de apriete máximo de montaje del sensor es de 7 Nm.

- ▶ Instale el sensor en la ubicación deseada. Tenga en cuenta la zona ciega s_{\min} en la cual no es posible detectar objetos (consulte technical data).
- ▶ Instale el sensor de tal manera que no haya objetos extraños en el rango de detección (consulte la fig. 3).

Conexión

NOTA

El dispositivo debe estar provisto de una fuente de alimentación SELV/PELV que cumpla los requisitos para un circuito de energía limitada según UL61010-1 3ª edición (IEC/EN 61010-1) o de una fuente de energía limitada de acuerdo con UL 62368-1 o Clase 2 de acuerdo con NEC.

- ▶ Conecte el dispositivo como se muestra en "Wiring diagrams".

Puesta en marcha

Una vez conectados los cables y encendida la alimentación, el dispositivo queda automáticamente operativo.

Funcionamiento

LED

LED PWR	Significado
Verde	Sensor listo para el funcionamiento (intensidad de la señal >108 dB)
Verde intermitente (4 Hz)	Intensidad de la señal <108 dB
Verde intermitente (1 Hz)	Intensidad de la señal <78 dB
Amarillo	Salida 2 activa
Amarillo intermitente	Cortocircuito en la salida 2

LED COM	Significado
Verde	Modo SIO
Verde intermitente (5 Hz)	Conexión CAN activa
Verde intermitente (900 ms encendido/100 ms apagado)	Comunicación IO-Link activa
Amarillo	Salida 1 activa
Amarillo intermitente	Cortocircuito en la salida 1
Rojo intermitente	Conexión de bus interrumpida
Verde/rojo intermitente	Solicitud de dirección (solo J1939)

LED APP	Significado
Verde	Objeto dentro del rango de detección
Amarillo	Objeto en el rango 1
Amarillo intermitente	Objeto en el radio 1

Declaration of conformity

Hiermit erklärt die TURCK GmbH, dass die Radar-Scanner der Baureihe MR... der Richtlinie 2014/53/EU und den Radio Equipment Regulations 2017 entsprechen. Der vollständige Text der EU/UK-Konformitätserklärung ist unter der folgenden Internetadresse verfügbar: www.turck.com

Hereby, TURCK GmbH declares that the radar scanner series MR... are in compliance with Directive 2014/53/EU and Radio Equipment Regulations 2017. The full text of the EU/UK declaration of conformity is available at the following internet address: www.turck.com

FCC digital device limitations

FCC ID: YQ7-MR15Q80
IC ID: 8821A-MR15Q80

This device complies with Part 15 of the FCC Rules and Industry Canada license-exempt RSS standard(s). Operation is subject to the following two conditions:
(1) this device may not cause harmful interference, and
(2) this device must accept any interference received, including interference that may cause undesired operation.

Changes or modifications not expressly approved by the party responsible for compliance could void the user's authority to operate the equipment.

Visualizaciones de estado combinadas

PWR	COM	APP	Significado
Rojo (1 Hz)	Rojo (1 Hz)	Rojo (1 Hz)	Error de hardware interno
Luz de funcionamiento verde/amarilla/roja	Luz de funcionamiento verde/amarilla/roja	Luz de funcionamiento verde/amarilla/roja	Actualización de firmware activa
Verde/amarillo intermitente	Verde/amarillo intermitente	Verde/amarillo intermitente	Comando Wink para la identificación del producto dentro del sistema

Transferencia de datos a través de IO-Link SSP4

La transferencia de datos a través de IO-Link SSP4 utiliza cuatro canales:

Canal	Asignación
1	Distancia
2	Ángulo acimutal
3	Ángulo de elevación
4	Velocidad

Transferencia de datos a través de la interfaz SAE J1939

- La transferencia de datos a través de la interfaz SAE J1939 utiliza el grupo de parámetros PGN 0xFF20 (65315).
- Los datos del objeto son generados por el primer objeto o el más fuerte (dependiendo de la configuración del sensor) que se detecta dentro del rango de detección.

Byte	Asignación
0	Distancia
1	Distancia
2	Ángulo acimutal
3	Ángulo de elevación
4	Velocidad
5	Intensidad de la señal
6	Información de radio de advertencia (bits 2...7)
7	Información de campo de señal (bits 2...7)

Configuración y parametrización

La parametrización mediante IO-Link se explica en el manual de puesta en marcha de IO-Link. Las siguientes propiedades se pueden cambiar en el sensor para ajustar su comportamiento:

- supresión de vista frontal y de fondo
- supresión de ángulo (acimutal y elevación)
- filtro de intensidad de señal
- detección solo de objetos en movimiento o de todos los objetos
- 6 radios de aviso/alarma alrededor del sensor
- 3 campos de señal en el rango de detección

Mantenimiento

El dispositivo no necesita mantenimiento. Limpie con un paño húmedo, si es necesario.

Reparación

El dispositivo se debe desinstalar si presenta fallas. Solo TURCK puede reparar el dispositivo. Siga nuestras políticas de devolución cuando devuelva el dispositivo a TURCK.

Eliminación

Los dispositivos se deben desechar correctamente y no se deben mezclar con residuos domésticos normales.

Le présent appareil est conforme aux CNR d'Industrie Canada applicables aux appareils radio exempts de licence. L'exploitation est autorisée aux deux conditions suivantes :

- (1) l'appareil ne doit pas produire de brouillage, et
- (2) l'utilisateur de l'appareil doit accepter tout brouillage radioélectrique subi, même si le brouillage est susceptible d'en compromettre le fonctionnement.

Note:

This equipment has been tested and found to comply with the limits for a Class A digital device, pursuant to part 15 of the FCC Rules. These limits are designed to provide reasonable protection against harmful interference when the equipment is operated in a commercial environment.

This equipment generates, uses, and can radiate radio frequency energy and, if not installed and used in accordance with the instruction manual, may cause harmful interference to radio communications. Operation of this equipment in a residential area is likely to cause harmful interference in which case the user will be required to correct the interference at his own expense.

Radiofrequency radiation exposure Information:

This equipment complies with FCC radiation exposure limits set forth for an uncontrolled environment. This equipment should be installed and operated with minimum distance of 20 cm between the radiator and your body.

This transmitter must not be co-located or operating in conjunction with any other antenna or transmitter.

①



MR...
Radar Scanner
Quick Start Guide
Doc. no. 100045077

Additional information see



②

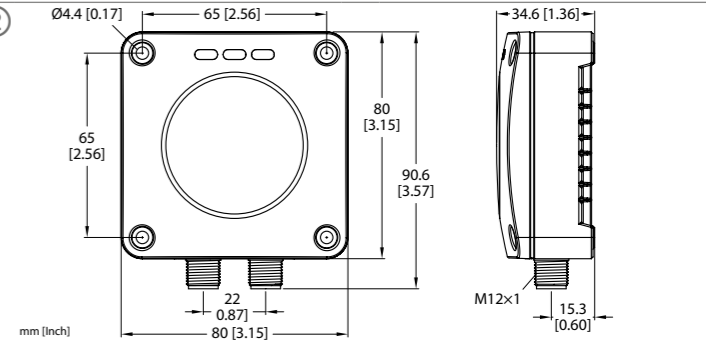

③

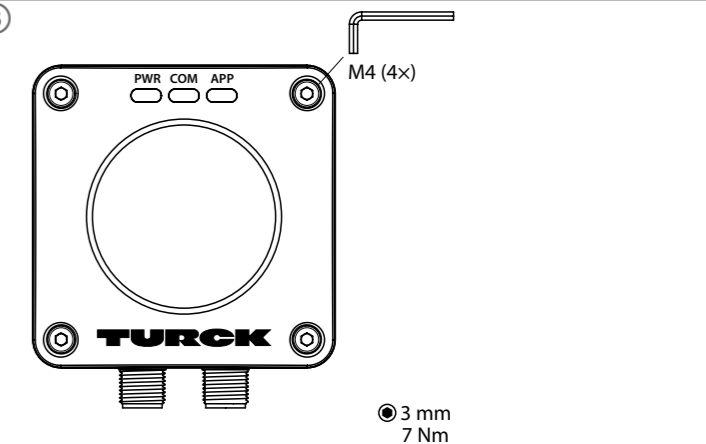

Wiring diagrams

Connector 1 (IO-Link and switching outputs)

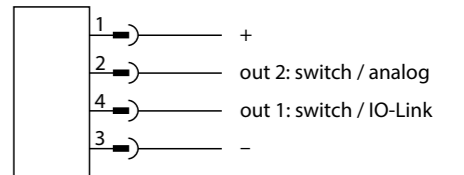
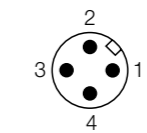

Connector 2 (SAE J1939)

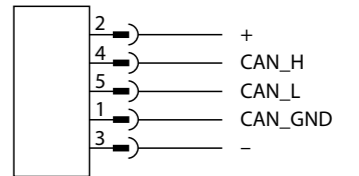
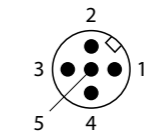

ZH 快速入门指南

雷达扫描仪MR...

其他文档

除了本文档之外,还可在www.turck.com.cn网站上查看以下材料:

- 数据表
- 使用说明
- IO-Link参数
- IO-Link调试手册
- 合规声明
- 产品认证

安全须知

预期用途

MR...产品系列中的雷达扫描仪可以非接触方式检测检测范围内是否有物体,并测量这些物体在空间中的位置。如果检测范围内有多个物体,您可以选择是评估离传感器最近的物体还是评估回声信号最强的物体。探测范围和物体探测可通过过滤器设置和传感器配置进行调整。

必须严格按照这些说明使用该装置。任何其他用途都不属于预期用途。图尔克公司不对非预期用途导致的任何损坏承担责任。

明显的误用

该装置不属于安全部件,不得用于个人防护。

一般安全须知

- 该装置的固定、安装、操作、参数设定和维护必须由经过培训的专业人员执行。
- 请勿将本装置用于人员保护或机器防护。
- 传感器发射的最大传输功率不超过ETSI EN 305550-2规定的允许限值。

UL认证说明

- 雷达传感器必须与列出的(CYJV/7或CYJV2/8)线缆/接插件组件一起使用,后者的额定值至少为36 VDC和500 mA,并适合最终安装中的应用。

产品描述

装置概览

参见图1:装置视图,图2:尺寸。

功能和工作模式

型号	输出
MR...Q80-IO-LCJ-H1141	IO-Link (SSP 4.1.1), 2路开关量输出, SAE J1939

该装置可检测所检测物体与传感器外壳末端之间的距离;它还可检测各自的方位角和仰角以及径向速度。对于开关量输出,可以为距离、角度或速度通道定义单个开关点、2路开关量输出或窗口功能。此外,还可通过IO-Link过程数据和SAE J1939协议将测量值发送至更高级别的控制系统。通过过程数据传输距离值(m)、角度(°)和速度(m/s)。

可通过IO-Link和SAE J1939协议对装置进行参数设置。

技术数据

测量范围	0.35...15 m
盲区s _{min}	350 mm
频率范围	60...64 GHz
分辨率	2 mm
迟滞	≤ 50 mm
环境温度	-40...+85 °C
工作电压	9...33 V (SELV/PELV)
功耗	最大30 W (内部13 W,外部17 W)
正常延迟	300 ms
公头接插件1	开关量输出和/或IO-Link
公头接插件2	SAE J1939
额定功率	≤ 400 mA (无负载输出) ≤ 900 mA (加载输出) ≤ 250 mA (每路输出的输出负载)
防护等级	IP67、IP69K (未根据IEC和UL标准进行评估)
重量	458 g
电磁兼容性(EMC)	EN 61000-6-2:2019 ETSI EN 301489-3 V1.6.1
相对湿度	0...99 % (相对值)
最高海拔	2000 m
污染程度	3
使用类型	室内/室外

安装

“TURCK”字标表示传感器的方位轴。

传感器可根据应用要求以任何对齐方式安装。雷达波垂直于雷达透镜表面传播。可根据客户规格设置检测范围的距离和角度。最大锥角限制为±60°(方位角)和±50°(仰角)。

安装传感器时的最大拧紧扭矩为7 Nm。

► 将传感器安装在预定位置。请注意盲区s_{min},在其中无法检测物体(参见Technical data)。

► 安装传感器时,应确保在检测范围内无异物(参见图3)。

连接

注意

该装置必须配备SELV/PELV电源,该电源需符合UL61010-1第3版(IEC/EN 61010-1)中关于限能电路的要求,或UL 62368-1中关于限功率电源的要求,或是符合NEC要求的2级电源。

► 按照“Wiring diagrams”连接该装置。

调试

一旦连接线缆并接通电源,该装置便会自动运行。

操作

PWR LED	含义
绿色	传感器准备运行 (信号强度> 108 dB)
绿灯闪烁(4 Hz)	信号强度< 108 dB
绿灯闪烁(1 Hz)	信号强度< 78 dB
黄灯	输出2激活
黄灯闪烁	输出2短路

COM LED	含义
绿色	SIO模式
绿灯闪烁(5 Hz)	CAN连接激活
绿灯闪烁(亮起900 ms/熄灭100 ms)	IO-Link通信激活
黄灯	输出1激活
黄灯闪烁	输出1短路
红灯闪烁	总线连接中断
绿灯/红灯闪烁	地址请求 (仅限J1939)

APP LED	含义
绿色	物体处于检测范围内
黄灯	物体处于范围1内
黄灯闪烁	物体处于半径1内

组合状态显示

PWR	COM	APP	含义
红灯(1 Hz)	红灯(1 Hz)	红灯(1 Hz)	内部硬件错误
绿色/黄色/红色	绿色/黄色/红色	绿色/黄色/红色	固件更新激活
运行灯	运行灯	运行灯	
绿灯/黄灯	绿灯/黄灯	绿灯/黄灯	闪烁命令,用于
闪烁	闪烁	闪烁	系统内部产品识别

通过IO-Link SSP4传输数据

通过IO-Link SSP4传输数据使用四个通道:

通道	分配
1	距离
2	方位角
3	仰角
4	速度

通过SAE J1939接口传输数据

- 通过SAE J1939接口传输数据使用参数组PGN 0xFF20 (65315)。
- 物体数据由在检测范围内检测到的第一个物体或信号最强的物体(取决于传感器设置)生成。

字节	分配
0	距离
1	距离
2	方位角
3	仰角
4	速度
5	信号强度
6	警告半径信息(位2...7)
7	信号场信息(位2...7)

设置和参数设定

IO-Link调试手册中介绍了通过IO-Link进行参数设置的方法。

可以更改传感器的以下属性以调整其行为:

- 前景和背景抑制
- 角度抑制(方位角和仰角)
- 信号强度滤波器
- 仅检测移动物体或检测所有物体
- 传感器周围的6个警告/警报半径
- 检测范围内的3个信号场

维护

该装置免维护。必要时可用湿布进行清洁。

维修

如果该装置出现故障,必须将其停用。该装置只能由图尔克公司进行维修。如果要将该装置退回给图尔克公司维修,请遵守我们的返修验收条件。

废弃处理

必须正确地弃置该装置,不得当作生活垃圾处理。

Declaration of conformity

Hiermit erklärt die TURCK GmbH, dass die Radar-Scanner der Baureihe MR... der Richtlinie 2014/53/EU und den Radio Equipment Regulations 2017 entsprechen. Der vollständige Text der EU/UK-Konformitätserklärung ist unter der folgenden Internetadresse verfügbar: www.turck.com

Hereby, TURCK GmbH declares that the radar scanner series MR... are in compliance with Directive 2014/53/EU and Radio Equipment Regulations 2017. The full text of the EU/UK declaration of conformity is available at the following internet address: www.turck.com

FCC digital device limitations

FCC ID: YQ7-MR15Q80
IC ID: 8821A-MR15Q80

This device complies with Part 15 of the FCC Rules and Industry Canada license-exempt RSS standard(s). Operation is subject to the following two conditions:
(1) this device may not cause harmful interference, and
(2) this device must accept any interference received, including interference that may cause undesired operation.

Changes or modifications not expressly approved by the party responsible for compliance could void the user's authority to operate the equipment.

Le présent appareil est conforme aux CNR d'Industrie Canada applicables aux appareils radio exempts de licence. L'exploitation est autorisée aux deux conditions suivantes :

- (1) l'appareil ne doit pas produire de brouillage, et
- (2) l'utilisateur de l'appareil doit accepter tout brouillage radioélectrique subi, même si le brouillage est susceptible d'en compromettre le fonctionnement.

Note: This equipment has been tested and found to comply with the limits for a Class A digital device, pursuant to part 15 of the FCC Rules. These limits are designed to provide reasonable protection against harmful interference when the equipment is operated in a commercial environment. This equipment generates, uses, and can radiate radio frequency energy and, if not installed and used in accordance with the instruction manual, may cause harmful interference to radio communications. Operation of this equipment in a residential area is likely to cause harmful interference in which case the user will be required to correct the interference at his own expense.

Radiofrequency radiation exposure Information:

This equipment complies with FCC radiation exposure limits set forth for an uncontrolled environment. This equipment should be installed and operated with minimum distance of 20 cm between the radiator and your body.

This transmitter must not be co-located or operating in conjunction with any other antenna or transmitter.

①



MR...
Radar Scanner
Quick Start Guide
Doc. no. 100045077

Additional
information see



②

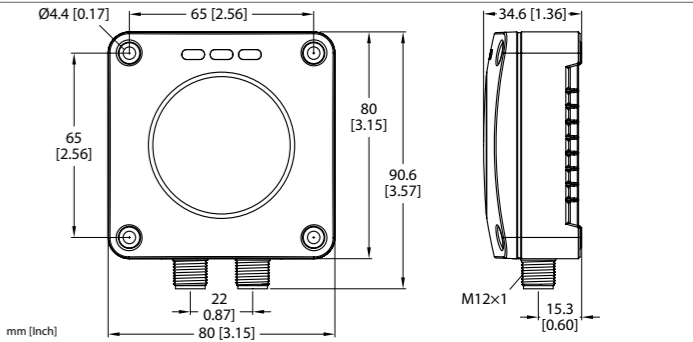

③

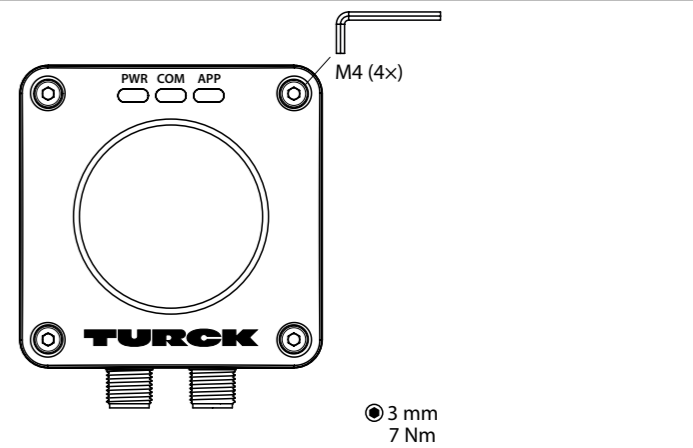

Wiring diagrams

Connector 1 (IO-Link and switching outputs)

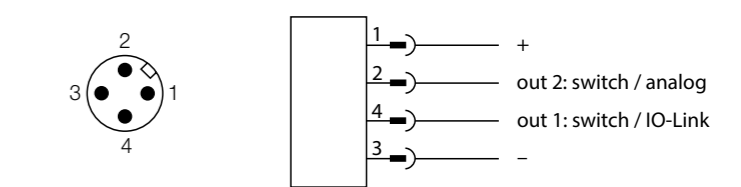

Connector 2 (SAE J1939)

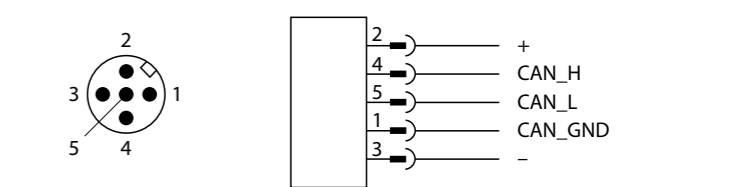

KO 빠른 시작 가이드

레이더 스캐너 MR...

기타 문서

이 문서 외에도 다음과 같은 자료를 인터넷(www.turck.com)에서 확인할 수 있습니다.

- 데이터 시트
- 사용 지침
- IO-Link 매개 변수
- IO-Link 시운전 매뉴얼
- 적합성 선언
- 인증

사용자 안전 정보

사용 목적

MR... 제품 시리즈의 레이더 스캐너는 접촉 없이 감지 범위 내에 있는 물체를 감지하고 공간 내에서 이러한 물체의 위치를 측정합니다. 감지 범위 내에 물체가 여러 개인 경우 센서와의 거리가 가장 가까운 물체를 평가할지 또는 에코 신호가 가장 강한 물체를 평가할지 선택할 수 있습니다. 감지 범위 및 물체 감지는 필터 설정 및 센서 구성을 통해 조정할 수 있습니다. 이 장치는 이 지침에서 설명한 목적으로만 사용해야 합니다. 기타 다른 방식으로 사용하는 것은 사용 목적을 따르지 않는 것입니다. 터크는 그로 인해 발생한 손해에 대해 책임을 지지 않습니다.

명백하게 부적절한 사용

이 장치는 안전용 구성 요소가 아니며 인명 보호 목적으로 사용해서는 안 됩니다.

일반 안전 지침

- 전문적인 훈련을 받은 숙련된 기술자만 이 장치의 조립, 설치, 작동, 매개 변수 설정 및 유지보수를 수행해야 합니다.
- 사람이나 장비를 보호하는 용도로 장치를 사용하지 마십시오.
- 센서에서 방출되는 최대 전송 전력은 ETSI EN 305550-2에 따른 허용 한계를 초과하지 않습니다.

UL 인증 참고 사항

- 레이더 센서는 최종 설치에 적합한 최소 정격 깊이 36 VDC 및 500 mA인 등록(CYJV/7 또는 CYJV2/8) 케이블/커넥터 어셈블리와 함께 사용해야 합니다.

제품 설명

장치 개요

그림 1: 장치 도면, 그림 2: 치수를 참조하십시오.

기능 및 작동 모드

타입	출력
MR...-Q80-IOLCJ-H1141	IO-Link(SSP 4.1.1), 스위칭 출력 2개, SAE J1939

이 장치는 감지된 물체와 센서 하우징 엔드 사이의 거리를 측정합니다. 또한 각각의 방위각, 고도각, 반경 방향 속도를 측정합니다. 스위칭 출력의 경우 거리, 각도, 속도 채널에 대해 단일 스위칭 포인트, 2개의 스위칭 출력 또는 윈도우 기능을 정의할 수 있습니다. 또한 측정된 값은 IO-Link 프로세스 데이터 및 SAE J1939 프로토콜을 통해 상위 레벨의 컨트롤 시스템으로 전송됩니다. 거리 값은 m 단위로, 각도는 ° 단위로, 속도는 m/s 단위로 프로세스 데이터를 통해 전송됩니다. 장치는 IO-Link 및 SAE J1939 프로토콜을 통해 매개 변수화할 수 있습니다.

기술 데이터

측정 범위	0.35...15 m
블라인드 존 s _{min}	350 mm
주파수 범위	60...64 GHz
해상도	2 mm
히스테리시스	≤ 50 mm
주변 온도	-40...+85 °C
작동 전압	9...33 V(SELV/PELV)
전력 소모량	최대 30 W(내부 13 W, 외부 17 W)
준비 지연	300 ms
male 커넥터 1	스위칭 출력 및/또는 IO-Link
male 커넥터 2	SAE J1939
정격 출력	≤ 400 mA (무부하 출력) ≤ 900 mA(부하 출력) ≤ 250 mA (출력당 출력 부하)

보호 등급	IP67, IP69K(IEC 및 UL에 따라 평가되지 않음)
무게	458 g
전자기파 적합성(EMC)	EN 61000-6-2:2019 ETSI EN 301489-3 V1.6.1
습도	0...99 %(상대)
최대 고도	2,000 m
오염도	3
사용 타입	실내/실외

설치

„TURCK“ 글자는 센서의 방위각 축을 나타냅니다.

이 센서는 애플리케이션 요구 사항에 따라 어떤 정렬에도 설치할 수 있습니다. 레이더 파동은 레이더 렌즈 표면에 수직으로 전파됩니다. 감지 범위의 거리 및 각도는 고객 사양에 따라 설정할 수 있습니다. 최대 원뿔각은 ±60°(방위각) 및 ±50°(고도각)로 제한됩니다.

센서를 설치할 때 최대 조임 토크는 7 Nm입니다.

▶ 원하는 위치에 센서를 설치하십시오. 물체가 감지되지 않는 블라인드 존 s_{min}을 주의하십시오(기술 데이터 참조).

▶ 감지 범위에 이물질이 없도록 센서를 설치하십시오(그림 3 참조).

연결

참고

이 장치에는 UL61010-1 3번째 버전(IEC/EN 61010-1) 규격의 제한된 에너지 회로 요구 사항, UL 62368-1 규격의 제한된 전원 요구 사항 또는 NEC 규격의 등급 2 요구 사항을 준수하는 SELV/PELV 파워 서플라이가 제공되어야 합니다.

▶ „Wiring diagrams“에 따라 장치를 연결하십시오.

시운전

케이블이 연결되고 파워 서플라이가 켜지면 장치가 자동으로 작동 가능해집니다.

작동 LED

PWR LED	의미
녹색	센서 작동 준비 완료(신호 강도 > 108 dB)
녹색 점멸(4 Hz)	신호 강도 < 108 dB
녹색 점멸(1 Hz)	신호 강도 < 78 dB
황색	출력 2 활성화
황색 점멸	출력 2에서 단락

COM LED	의미
녹색	SIO 모드
녹색 점멸(5 Hz)	CAN 연결 활성화
녹색 점멸(900 ms 켜짐/100 ms 꺼짐)	IO-Link 통신 활성화
황색	출력 1 활성화
황색 점멸	출력 1에서 단락
적색 점멸	버스 연결 중단됨
녹색/적색 점멸	주소 요청(J1939만 해당)

APP LED	의미
녹색	감지 범위 내에 있는 물체
황색	범위 1 내에 있는 물체
황색 점멸	반경 1 내에 있는 물체

결합된 상태 표시

PWR	COM	APP	의미
적색(1 Hz)	적색(1 Hz)	적색(1 Hz)	내부 하드웨어 오류
녹색/황색/적색	녹색/황색/적색	녹색/황색/적색	펌웨어 업데이트 활성화
작동 표시등	작동 표시등	작동 표시등	
녹색/황색	녹색/황색	녹색/황색	시스템 내부의 제품 식별을 위한 Wink 명령
점멸	점멸	점멸	

IO-Link SSP4를 통한 데이터 전송

IO-Link SSP4를 통한 데이터 전송은 다음과 같이 4개의 채널을 사용합니다.

채널	할당
1	거리
2	방위각
3	고도각
4	속도

SAE J1939 인터페이스를 통한 데이터 전송

- SAE J1939 인터페이스를 통한 데이터 전송은 매개 변수 그룹 PGN 0xFF20(65315)를 사용합니다.
- 물체 데이터는 감지 범위 내에서 감지된 첫 번째 물체 또는 신호가 가장 강한 물체(센서 설정에 따라 다음)에 의해 생성됩니다.

Byte	할당
0	거리
1	거리
2	방위각
3	고도각
4	속도
5	신호 강도
6	경고 반경 정보(Bits 2...7)
7	신호 필드 정보(Bits 2...7)

설정 및 매개 변수화

IO-Link를 통한 매개 변수화는 IO-Link 시운전 매뉴얼에 설명되어 있습니다.

센서에서 다음과 같은 속성을 변경하여 센서 거동을 조정할 수 있습니다.

- 전경 및 후경 무시 기능
- 각도 억제(방위각 및 고도각)
- 신호 강도 필터
- 움직이는 물체만 감지 또는 모든 물체 감지
- 센서 주변의 6가지 경고/경보 반경
- 감지 범위 내의 3가지 신호 필드

유지보수

이 장치는 유지보수가 필요하지 않습니다. 필요한 경우 젖은 천으로 닦으십시오.

수리

이 장치에 고장이 발생한 경우 설치 해제해야 합니다. 이 장치는 터크에서만 수리할 수 있습니다. 장치를 터크로 반품할 경우 당사의 반품 정책을 참조하십시오.

폐기

이 장치는 적절하게 폐기해야 하며 가용 폐기물에 해당하지 않습니다.

①



MR... Radar Scanner
Quick Start Guide
Doc. no. 100045077

Additional information see



②

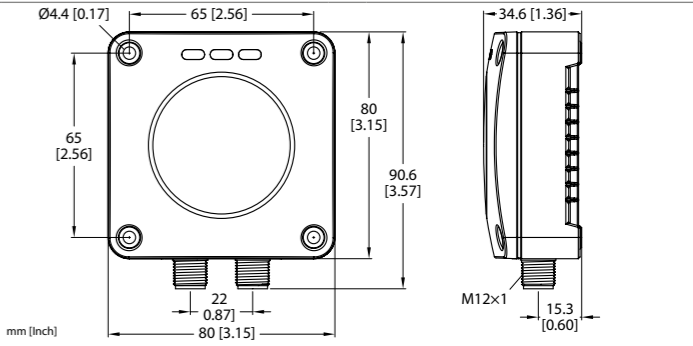

③

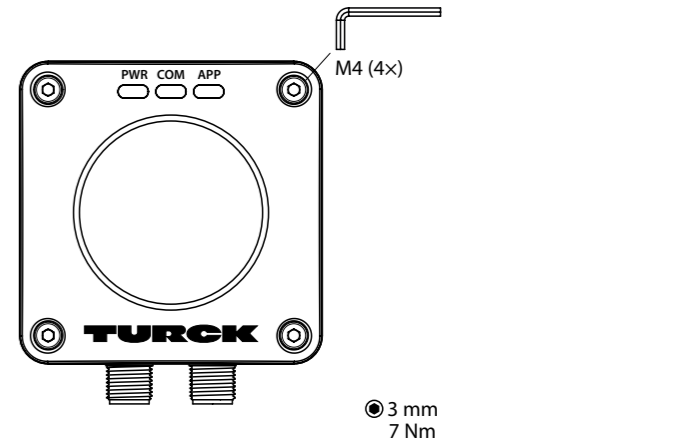

Wiring diagrams

Connector 1 (IO-Link and switching outputs)	

Connector 2 (SAE J1939)	

Declaration of conformity

Hiermit erklärt die TURCK GmbH, dass die Radar-Scanner der Baureihe MR... der Richtlinie 2014/53/EU und den Radio Equipment Regulations 2017 entsprechen. Der vollständige Text der EU/UK-Konformitätserklärung ist unter der folgenden Internetadresse verfügbar: www.turck.com

Hereby, TURCK GmbH declares that the radar scanner series MR... are in compliance with Directive 2014/53/EU and Radio Equipment Regulations 2017. The full text of the EU/UK declaration of conformity is available at the following internet address: www.turck.com

FCC digital device limitations

FCC ID: YQ7-MR15Q80
IC ID: 8821A-MR15Q80

This device complies with Part 15 of the FCC Rules and Industry Canada license-exempt RSS standard(s). Operation is subject to the following two conditions:
(1) this device may not cause harmful interference, and
(2) this device must accept any interference received, including interference that may cause undesired operation.

Changes or modifications not expressly approved by the party responsible for compliance could void the user's authority to operate the equipment.

Le présent appareil est conforme aux CNR d'Industrie Canada applicables aux appareils radio exempts de licence. L'exploitation est autorisée aux deux conditions suivantes :

- l'appareil ne doit pas produire de brouillage, et
- l'utilisateur de l'appareil doit accepter tout brouillage radioélectrique subi, même si le brouillage est susceptible d'en compromettre le fonctionnement.

Note: This equipment has been tested and found to comply with the limits for a Class A digital device, pursuant to part 15 of the FCC Rules. These limits are designed to provide reasonable protection against harmful interference when the equipment is operated in a commercial environment. This equipment generates, uses, and can radiate radio frequency energy and, if not installed and used in accordance with the instruction manual, may cause harmful interference to radio communications. Operation of this equipment in a residential area is likely to cause harmful interference in which case the user will be required to correct the interference at his own expense.

Radiofrequency radiation exposure Information:

This equipment complies with FCC radiation exposure limits set forth for an uncontrolled environment. This equipment should be installed and operated with minimum distance of 20 cm between the radiator and your body.

This transmitter must not be co-located or operating in conjunction with any other antenna or transmitter.